

RoHS

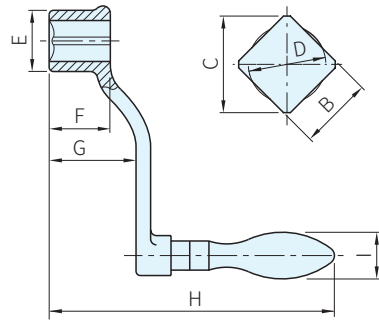
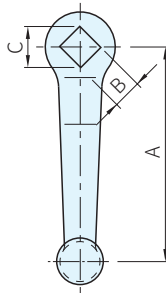

| 本體 | | | 把手 | |
|----|----|----|----|----|
| 材質 | 處理 | 顏色 | 材質 | 處理 |
| 鑄鐵 | 噴砂 | 黑 | 鋼 | 鍍鋅 |

| 品號 | 特性 | A | B H11 | C MIN. | D | E | F | G | H | I | 質量 g | 庫存 |
|------------|------------------|------------------|----------|-----------|------|-----|----|-----|-----|-----|---------|-----|
| 24330.0210 | 有迴轉把手 (24460) | 63 | 10 | 13.1 | 10.5 | 20 | 20 | 32 | 96 | 16 | 118 | • |
| 24330.0220 | | 80 | 24 | 24 | 38 | 116 | 18 | 201 | • | | | |
| 24330.0221 | | 12 | 16.1 | 12.6 | 28 | 28 | 48 | 126 | 20 | 200 | • | |
| 24330.0230 | | 100 | 14 | 18.1 | 14.7 | 34 | 34 | 55 | 150 | 22 | 310 | • |
| 24330.0231 | | 125 | 17 | 22.2 | 17.9 | 38 | 38 | 65 | 160 | 25 | 291 | • |
| 24330.0240 | | 160 | 19 | 25.2 | 20 | 44 | 44 | 78 | 202 | 28 | 464 | • |
| 24330.0241 | | 200 | 22 | 28.2 | 23.1 | 48 | 48 | 90 | 214 | 32 | 455 | • |
| 24330.0250 | | 250 | 24 | 32.2 | 25.3 | 48 | 48 | 90 | 214 | 32 | 674 | • |
| 24330.0251 | | 24 | 32.2 | 25.3 | 48 | 48 | 90 | 214 | 32 | 664 | • | |
| 24330.0260 | | 63 | 10 | 13.1 | 10.5 | 20 | 20 | 32 | 92 | 16 | 1083 | • |
| 24330.0261 | | 80 | 12 | 16.1 | 12.6 | 24 | 24 | 38 | 114 | 18 | 1034 | • |
| 24330.0270 | | 100 | 14 | 18.1 | 14.7 | 28 | 28 | 48 | 124 | 20 | 1497 | • |
| 24330.0271 | | 125 | 17 | 22.2 | 17.9 | 34 | 34 | 55 | 148 | 22 | 1478 | • |
| 24330.0310 | | 有固定把手 (24450) | 160 | 19 | 25.2 | 20 | 38 | 38 | 65 | 158 | 25 | 661 |
| 24330.0320 | 200 | | 22 | 28.2 | 23.1 | 44 | 44 | 78 | 197 | 28 | 627 | • |
| 24330.0321 | 250 | | 24 | 32.2 | 25.3 | 48 | 48 | 90 | 209 | 32 | 1020 | • |
| 24330.0330 | 63 | | 10 | 13.1 | 10.5 | 20 | 20 | 32 | 92 | 16 | 1004 | • |
| 24330.0331 | 80 | | 12 | 16.1 | 12.6 | 24 | 24 | 38 | 114 | 18 | 1438 | • |
| 24330.0340 | 100 | | 14 | 18.1 | 14.7 | 28 | 28 | 48 | 124 | 20 | 1415 | • |
| 24330.0341 | 125 | | 17 | 22.2 | 17.9 | 34 | 34 | 55 | 148 | 22 | | |
| 24330.0350 | 160 | | 19 | 25.2 | 20 | 38 | 38 | 65 | 158 | 25 | | |
| 24330.0351 | 200 | | 22 | 28.2 | 23.1 | 44 | 44 | 78 | 197 | 28 | | |
| 24330.0360 | 250 | | 24 | 32.2 | 25.3 | 48 | 48 | 90 | 209 | 32 | | |
| 24330.0361 | | | | | | | | | | | | |
| 24330.0370 | | | | | | | | | | | | |
| 24330.0371 | | | | | | | | | | | | |

PS. 備註

- ・本體毛邊研磨及噴砂處理
- ・迴轉把手24460，請參閱把手單元
- ・固定把手24450，請參閱把手單元

 訂貨： 交期：

24330.0210